

Name \_\_\_\_\_

OREGON STATE UNIVERSITY

DEPARTMENT OF CHEMISTRY

## Experiment 2B

## Integrated Laboratory Experiment

## DETERMINATION OF RIBOFLAVIN: A COMPARISON OF TECHNIQUES

## PART B. MOLECULAR FLUORESCENCE SPECTROSCOPY

I.	Introduction	2
II.	Solutions	4
III.	Instrumentation	5
IV.	Excitation Spectrum	7
V.	Emission Spectrum	9
VI.	Calibration Data	10
VII.	Detection Limit	13
VIII.	Lab Report	13
	Data Sheet	16
	Summary Sheet	18

## EXPERIMENT 2B. MOLECULAR FLUORESCENCE SPECTROMETRY

### I. INTRODUCTION

**Fluorescence** is observed when a sample emits light after absorption of light. Fluorescence is one of the possible mechanisms by which a molecule that is promoted to an excited electronic state by absorption of a photon can return to its ground state. Only a relatively small fraction of molecules exhibit substantial fluorescence because radiationless deactivation processes are often more favored.

In **fluorometry**, the sample is illuminated with excitation light of certain wavelengths. Normally a small fraction of the excitation light is absorbed. Fluorescence light is then emitted at a longer wavelength in all directions and a fraction of that is collected and directed to a photodetector (usually a PMT). The photocurrent is then processed to yield a voltage signal proportional to the fluorescence emitted.

#### *Signal Expressions and Calibration Curves*

The relationship between the fluorescence radiant power reaching the transducer,  $\Phi_f$ , and instrumental and chemical parameters is derived as follows. It is assumed that only a single absorbing and fluorescing species is present in the solution. The radiant power transmitted through the solution is found from Beer's law,

$$\Phi_s = \Phi_r T = \Phi_r 10^{-\epsilon bc} \quad (1)$$

where  $\Phi_r$  and  $\Phi_s$  are the radiant power passed by a blank and sample solution, respectively, and all other terms are defined in Experiment 2A. Hence, the radiant power absorbed by the solution is given by

$$\Phi_r - \Phi_s = \Phi_r (1 - 10^{-\epsilon bc}) \quad (2)$$

A certain fraction of the radiant power absorbed by the molecules in the solution results in fluorescence of which a fraction of that is seen by the detector. Therefore, the fluorescence radiant power seen by the detector is given by

$$\Phi_f = K \phi \Phi_r (1 - 10^{-\epsilon bc}) \quad (3)$$

where  $\phi$  is the **quantum efficiency of fluorescence**, specific for the analyte,  $K$  is an instrumental constant that accounts for the fraction of the total fluorescence radiation emitted in the cell that is incident on the transducer, and  $\Phi_r$  is effectively the excitation radiant power incident on the sample.

If the transducer is a photomultiplier tube (PMT) which is then connected to a signal processor that has a transfer function  $G$  in V/A, the fluorescence signal voltage is given by

$$E_f = \Phi_f R(\lambda) mG \quad (4)$$

Substitution of eq. 3 into eq. 4 yields

$$E_f = mGR(\lambda)K \phi \Phi_f(1 - 10^{-\epsilon bc}) = k'(1 - 10^{-\epsilon bc}) \quad (5)$$

where  $k'$  (or  $mGR(\lambda)K\phi\Phi_f$ ) is a constant for fixed instrumental settings (e.g., slit width, wavelength) and a given analyte. Note that  $R(\lambda)$ ,  $\Phi_f$ ,  $\phi$  and  $\epsilon$  are dependent on wavelength. Equation 5 does not account for the inner filter effect which is discussed in lecture.

If the absorbance at the excitation wavelength is small (e.g., at low concentrations), eq. 5 reduces to eq. 6 with about 1% accuracy for  $A = 0.01$  or about 5% accuracy for  $A = 0.05$  (1-cm pathlength assumed)

$$E_f = 2.303 k' \epsilon bc \quad (6)$$

and a direct proportionality exists between the fluorescence signal voltage ( $E_f$ ) and  $c$ . If the analyte absorbance at analyte concentration  $y$  is known or can be estimated, it can be used in eqs. 5 and 6 to calculate relative fluorescence signals to compare and estimate the expected degree of nonlinearity.

### *Spectra*

In fluorometric analysis, both the **excitation wavelength** and the **emission wavelength** (wavelength for fluorescence emission) must be chosen because the magnitude of the fluorescence radiant power,  $\Phi_f$ , depends on both quantities. Hence, prior to quantitative analysis, both an **excitation spectrum** and an **emission spectrum** must be obtained to determine  $\lambda_{\max}$  for both excitation and emission. The shape and relative size of bands of a given spectrum depend on both the characteristics of the molecule of interest and of the specific spectrometer used to obtain the spectrum. If the term "**corrected**" is added (e.g., corrected excitation spectrum), it means that the spectrum has been modified to eliminate the effect of instrumental characteristics (e.g., due to the variation of the source intensity with wavelength) on the shape and relative intensities of bands. If the correction is done well, the shape of the spectrum will be due to the molecule and not the instrument.

### *Background Signals*

The fluorescence signal from the analyte must be distinguished from two types of background radiation: **scattering** and **background fluorescence**. Scattering of the radiation from the excitation source by the sample gives rise to a background scattering signal,  $E_{sc}$ . During an excitation or emission scan, a peak due to the elastic scattering signal occurs **when the emission monochromator wavelength is the same as the excitation wavelength** and when the emission monochromator wavelength is at the appropriate setting to pass second-order radiation from the excitation source.

For quantitative measurements, the observed scattering signal should be small because the emission monochromator is set to a wavelength longer than that of the excitation monochromator. Non-analyte species in the solution, or in some cases the sample cell itself, may also be excited to fluorescence and yield an unwanted background fluorescence signal,  $E_{bf}$ , which can occur over a broad wavelength range.

Overall, the total signal from an analyte solution is

$$E_t = (E_f + E_{bf} + E_{sc} + E_d) = E_f + E_{bk} \quad (7)$$

A proper blank measurement for  $E_{bk}$  yields the sum of the background and dark signals

$$E_{bk} = E_b + E_d \quad (8)$$

where  $E_b = E_{bf} + E_{sc}$ .

In this experiment the fluorescent behavior of riboflavin (vitamin B2) in water is investigated. Excitation and emission spectra are obtained. The relationship between fluorescence radiant power and concentration is studied, and from a calibration plot, the concentrations of riboflavin in a synthetic unknown solution and in a vitamin pill are determined.

## II. SOLUTIONS

The following stock solutions are available in the main laboratory: 100, 75, 25, and 10  $\mu\text{g/mL}$  riboflavin in MP water. When preparing solutions, use volumetric pipets and flasks throughout; avoid the use of soap in cleaning glassware or rinse extremely well, because soap has fluorescent components. Prepare:

- a) 2.50, 1.00, 0.250, and 0.100  $\mu\text{g/mL}$  riboflavin standard solutions in water from higher concentration stock or standard solutions (listed above) and MP water; use 50- or 100-mL volumetric flasks. Have a TA check your dilution scheme before proceeding. Once prepared, transfer these standard solutions to prepared amber bottles and store in refrigerator if you do not use them today or if you need the volumetric flasks for other solutions.
- b) one "Experiment 2B" synthetic unknown sample by quantitatively transferring the total contents of the vial to a 100-mL volumetric flask and diluting to volume with mp water.
- c) 1:100 dilutions of solutions X1, X2, and X3 (original stock solutions you prepared last week) and label these Z1, Z2, and Z3; use 100-mL volumetric flasks. Check your work with instructor for modifications.

Place the blank (MP water) in a labeled wash bottle. **Use a fresh blank solution each day as the blank can become contaminated over time.**

### III. INSTRUMENTATION

#### A. Spectra on commercial instrument

Spectra will be obtained with both a commercial spectrofluorometer and a fluorometer you will build with components at your stations. The station PTR instrument will also be used for quantitative measurements.

The commercial spectrofluorometer (Perkin-Elmer LS50B) is in GBAD 318 and a TA will guide one group at a time through the operation of this instrument. The instrument uses a 7-W Xe flash arc lamp as the source. With  $0.25 \mu\text{g/mL}$  riboflavin, obtain an excitation spectrum ( $300$  to  $550 \text{ nm}$  with  $\lambda_{\text{em}} = 525 \text{ nm}$ ) and an emission spectrum ( $400$  to  $650 \text{ nm}$  with  $\lambda_{\text{ex}} = 446 \text{ nm}$ ). Use slits providing a  $10\text{-nm}$  spectral bandpass for both monochromators and scan at  $500 \text{ nm/min}$ . Optimize wavelengths if necessary. Print spectra for each member in your group and be sure the Y-axis goes down to zero.

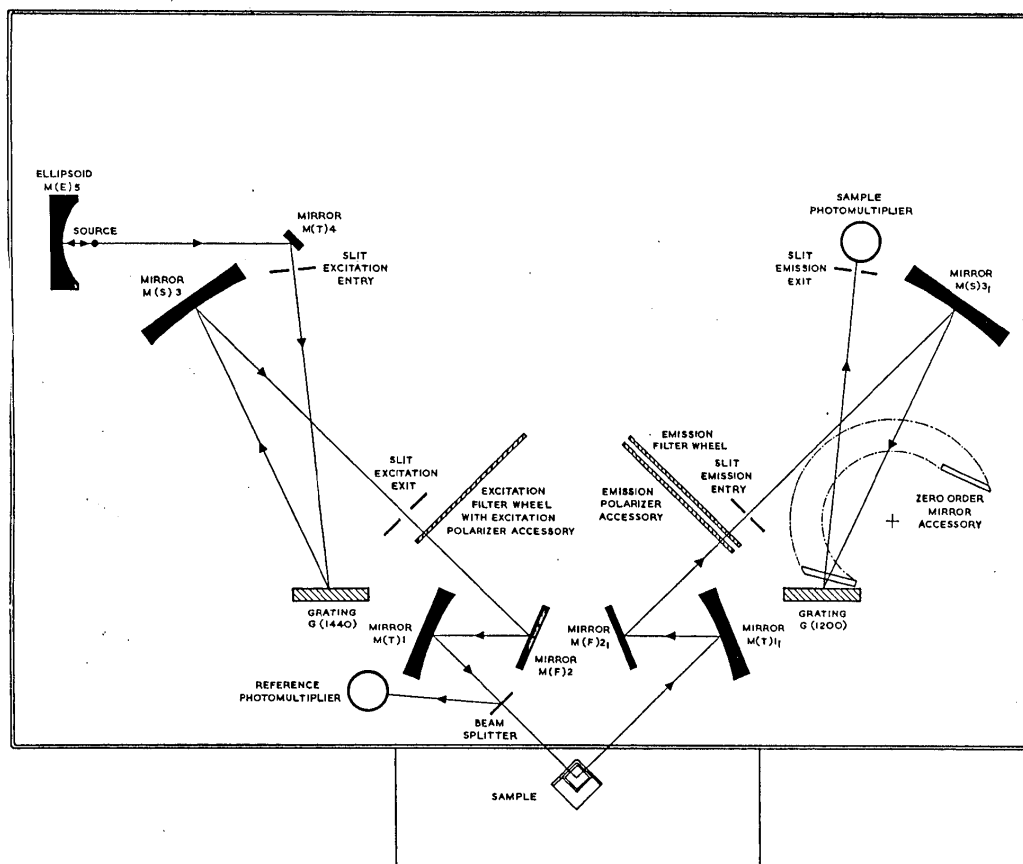

Figure 1. Block Diagram of Perkin Elmer LS50B Spectrofluorometer

### B. Spectra on PTR fluorometric instrumentation

The block diagrams of the PTR instrumentation at your station that you will use to obtain excitation and emission spectra are shown in Figures 2 and 3. The use of a tungsten lamp as the excitation source affords a good detection limit but is less than ideal because it is less intense than the source in commercial fluorometers. Also in the commercial fluorometer, the signal is “corrected” for the variation in the lamp intensity with wavelength during an excitation scan.

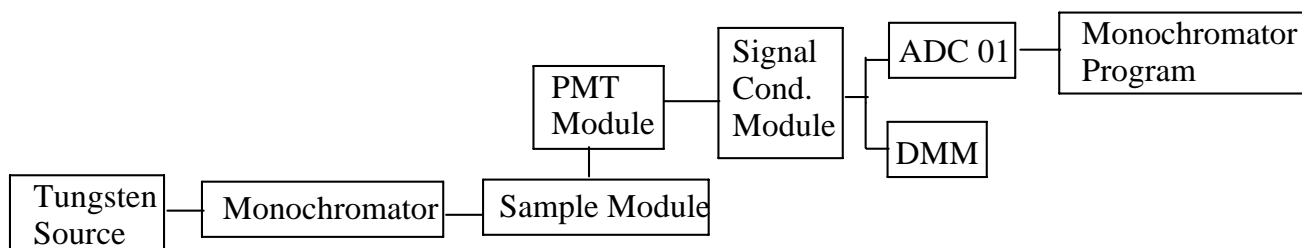

Figure 2. Instrumental Configuration for Excitation Spectra. Notice the 90° angle between the optical beams entering and leaving the sample module.

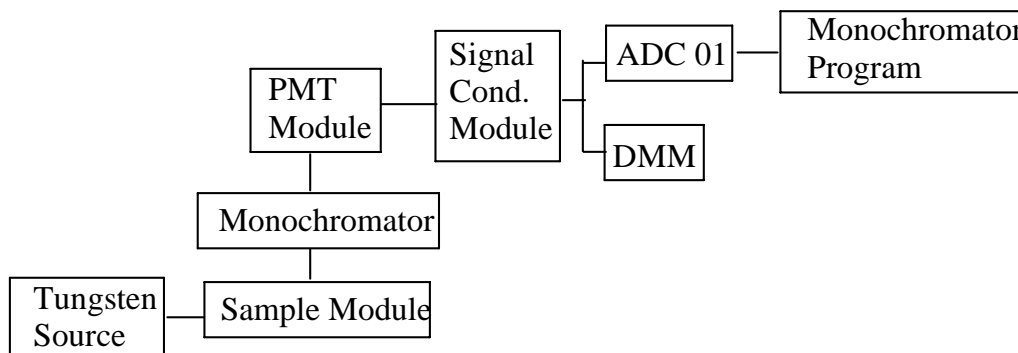

Figure 3. Instrumental Configuration for Emission Spectra

The spectra you obtain with the PTR fluorometer will look different from those obtained with the commercial spectrofluorometer because of differences in the configuration and characteristics of the optical components. First, different types of excitation sources are used (i.e., different dependence of source intensity on wavelength). Note in eqs. 5 and 6 that  $E_f$  depends on the source intensity ( $\Phi_i$ ). Spectra for the Xe and the tungsten source lamps are compared in a document under supplementary materials on the course web page. Second, only one monochromator is used for the PTR fluorometer for each type of spectrum. This means that scattering peaks will not be obvious with the PTR fluorometer (i.e., for an emission spectrum, all excitation source wavelengths are simultaneously incident on the sample and scattered).

#### IV. EXCITATION SPECTRUM

An **excitation spectrum** is represented by a plot of  $E_f$ , the emission signal, versus exciting wavelength with the fluorescence emission wavelength kept constant. This spectrum is used to find the best excitation wavelength to excite the sample. Set up the instrument as shown in Figure 2. **Before starting, check the following:**

- all filters are removed from the sample module
- PMT voltage is turned off while you are setting up
- aperture blocker is installed in the sample module port opposite from the light source
- hole in the bottom of the PMT module is blocked with a set screw
- three lenses are installed inside the sample module
- the PMT module is connected to **+IN** on the SCM and **-IN** is switched to ground

Check with an instructor if you have any difficulty understanding the above checks or if one of these statements is not true. Note that the monochromator is used to select the excitation wavelengths to be incident on the sample. Observe also that the PMT is at a right angle with respect to the source-monochromator-sample cell axis and views all wavelengths emitted or scattered by the sample. Use the following instrumental settings:

PMT HV bias voltage setting: 500-800 V	PMT Gain switch: VAR
Entrance and Exit Slit widths of PTR monochromator: 600 $\mu\text{m}$	
SCM Gain: 1 (check this)	SCM Filter Cutoff Frequency: 1 Hz (check this)
ADC Channel 0 and select Dev1/ai0, +/- 10 V in Monochromator Program	DMM: 20 V range

Turn the excitation lamp on and let the instrument warm up 5 min. Rinse the sample cell 3 times with 1 - 2 mL of the 25  $\mu\text{g}/\text{mL}$  solution of riboflavin and finally fill the sample cell with 3 - 4 mL of this solution. Place the sample cell in the sample module and put the lid on.

Use the **Monochromator program** in the CH 461 folder to set the wavelength, to optimize the wavelength and to perform scans. In Monochromator select +/- 10V for the full scale ADC voltage, Dev1/ai0, and make sure that the SCM signal goes to both the DMM and to Channel 0 of the ADC. **The following is important so do this carefully:**

- A. Send the monochromator to 450 nm (roughly the excitation peak maximum) and adjust the bias voltage and/or the gain control on the PMT module so that the DMM reads a signal of about 4 V.
- B. Check the alignment of the lamp, the monochromator and the cell compartment to maximize the signal. If necessary, readjust the PMT to get about 4 V at the DMM.
- C. Next, close the shutter and if necessary adjust the PMT zero (small black knob on PMT module) so the DMM reads about 0 V with the shutter closed. Reopen the shutter and recheck that the DMM signal is still about 4 V, re-adjusting if necessary to make sure that the DMM signal is around 4 V.

Do a trial scan from 430 to 470 nm at 100 nm/min (sta 1-6) or 150 nm/min (sta 7) to check that the maximum signal will be about 4 V on the Monochromator program display during the scan. If it is not, readjust the signal using the PMT gain. Recheck the PMT zero by closing the shutter.

Now open the shutter and perform an excitation scan from 250 to 750 nm at 100 nm/min sta 1-6 ( or 150 nm/min at sta 7) with the 25  $\mu\text{g}/\text{mL}$  standard riboflavin solution in the cell. (Note: the observed dip in the excitation band is expected because there is a decrease in the optical efficiency for the grating in the monochromator over this small wavelength range). When the scan finishes, enter a label for the scan in the "notes" field in the program and **save the data** in your folder. **Caution: Turn off the PMT bias voltage before you open the lid.** In the next section, you will record the emission spectrum and then using Excel to plot both the emission spectrum and the excitation spectrum on the same graph.

## V. EMISSION SPECTRUM

The **emission spectrum** is obtained by holding the excitation wavelength constant and recording  $E_f$  versus  $\lambda$ . It is used to determine the best emission wavelength to use for analysis. Set up the instrument according to Figure 3. **Caution: Turn off the PMT bias voltage before you open the lid.** Note that now the monochromator position is configured to select the emission wavelengths that the PMT views and that source radiation at all wavelengths is incident on the sample. Unscrew the monochromator baseplate and remove the set screw from the bottom of the PMT module. Attach the PMT module to the monochromator baseplate via a bolt through the bottom of the baseplate. You will also need to move the tungsten lamp source closer to the sample module excitation entrance port.

Remove, empty, rinse, and fill the sample cell with 3 - 4 mL of fresh 25  $\mu\text{g/mL}$  riboflavin solution. Use the same initial settings as in section IV except set the monochromator wavelength to 530 nm. **The following is important: Turn on the PMT and adjust the PMT bias voltage and/or gain so that the DMM reads about 4 V, and optimize the lamp and cell compartment positions and if needed, readjust to produce a 4 V signal. Check the PMT zero.**

Record the emission scan from 250 to 750 nm. You should observe that the fluorescence emission band of riboflavin appears at a longer wavelength than the excitation band. Note that there is no scatter peak as observed with the commercial spectrofluorometer because no excitation monochromator was used for the emission scan. **Save the data in your folder.** Later you will open each data file in Excel and plot both the excitation and the emission scans on the same chart.

**This is a convenient stopping point for the first day. Turn off power to all units. Leave your station setup for next time.**

## VI. CALIBRATION DATA

Fluorometric quantitative analysis is usually performed under conditions where there is a linear relationship between fluorescence radiant power and concentration (Equation 6). The data for the 0.1 to 1.0  $\mu\text{g/mL}$  riboflavin solutions will be used to construct a linear calibration curve. Concentrations above 2.5  $\mu\text{g/mL}$  will be measured to characterize the nonlinear region. Note that 25  $\mu\text{g/mL}$  riboflavin will be used initially to set the gain because it should yield the largest signal even though it is not the largest concentration you will measure. Bring all your solutions into the laboratory but keep the solutions shielded from light in a drawer until you need them.

### **Construct the filter spectrometer for calibration:**

To improve the detection limit, you will construct a filter-based **fluorometer** which does not use monochromators but rather an emission filter and an excitation filter so that more light reaches the PMT. First make sure that the PMT bias voltage is turned off. Use the same instrumental setup and settings as in Section V **except**

- remove the monochromator and attach the PMT module directly to the sample module at the emission exit port
- check that the hole in the bottom of the PMT module is blocked
- use the digital multimeter on the 50-V dc scale as the readout device (disconnect the ADC)
- change the PMT gain switch to the X1 position
- set the SCM cutoff frequency to 0.3 Hz (record this on the data sheet)
- insert a 408-nm blue band filter (transmits from about 340 to 480 nm) in the holder just inside the sample compartment on the excitation entrance port
- on the emission exit port, insert a 495-nm yellow cut-on filter that transmits light above 500 nm

### **Optimize the PMT detector bias voltage.**

1. Insert the cell using 3 - 4 mL of 25  $\mu\text{g/mL}$  riboflavin
2. Before turning on the PMT, check visually that the excitation light beam is passing down the center of the cell. Make sure the blue filter is used for selecting the excitation wavelength and the yellow filter for emission.

3. Put the lid on the sample compartment and turn the PMT on. Set the PMT module gain to X1 and adjust the PMT bias voltage so that the total signal is between 3 and 4 V -- check with an instructor if not. The bias voltage should be about - 400 to - 600 V. **Record the PMT bias voltage on the datasheet, and DO NOT CHANGE THE PMT BIAS VOLTAGE FOR THE REMAINDER OF THIS EXPERIMENT (or you will need to start the calibration over).**

**Cautions. Please read before starting measurements:**

- riboflavin solutions can photo-degrade, so make your measurements soon after you place the test solutions in the light beam (note the large dynamic concentration range of fluorescence compared to that for absorption)
- **for test solutions with concentrations below 10  $\mu\text{g}/\text{mL}$ , increase the signal conditioning gain (g) to the value shown in the Table I on data sheet**
- if any signal exceeds 10 V, reduce the SCM gain (g) and record the new SCM gain value
- the blank is measured for each test solution and must be measured with the same SCM gain as used for the test solution
- rinse well with blank solution between runs to prevent contamination from the previous test solution

**Measurement protocol for  $E_t$  for all the solutions and blanks in Table 1 on data sheet.**

1. Turn the PMT off, remove the lid, and rinse the cell several times with blank solution.
2. Fill the cell with 3 - 4 mL of blank.
3. Put the lid on, turn the PMT on, close the shutter and record the dark current voltage ( $E_d$ ) at the bottom of the datasheet (measure  $E_d$  only once).
4. Open the shutter and read the total voltage ( $E_{bk}$ ) for the blank for the first test solution in Table I and record  $E_t$ . Turn the PMT off. Remove the lid.

5. Rinse the cell with the blank and fill with the next test solution to be measured.
6. Put the lid on, turn on the PMT, and read the total voltage ( $E_t$ ) and record in Table I.  
**Use the same sample cell throughout all measurements.**
7. Repeat steps 1-6 (not 3) for the rest of the test solutions in Table 1 by alternating sample and blank solution measurements in the order given in the table. If the signal is noisy, take 5 readings and find the mean and record in Table I. Make sure to use the gain setting listed in Table 1 (it changes depending on the concentration range).

Prepare and update a spreadsheet with the data as you proceed. Also include a column denoted R which is the ratio of the normalized signal for a given B2 concentration to the normalized signal for a B2 concentration of  $1.0 \mu\text{g/mL}$ .

**It is absolutely critical that you should check the quality of your data as follows:**

- the calibration curve should be linear for  $0.1$ ,  $0.25$ , and  $1.0 \mu\text{g/mL}$  - the ratio R should vary from  $0.10$  to  $1.0$  in a linear fashion
  - all the blank signals for a given SCM gain should be very similar
  - the blank signal with an SCM gain of  $100$  should be less than  $0.5 \text{ V}$  but greater than  $0.010 \text{ V}$
8. Measure the synthetic unknown and the three vitamin tablet solutions (Z) right after completing the  $0.1$ ,  $0.25$ , and  $1.0 \mu\text{g/mL}$  riboflavin measurements. From the corrected fluorescence signal for the synthetic unknown and your calibration equation, determine the concentration of riboflavin in this unknown solution. Check this value with an instructor to see if you are within  $5\%$  of the correct value. If your result is not acceptable, you need to address the situation with your instructor and ultimately demonstrate that you can obtain an acceptable value.

## VII. DETECTION LIMIT

Connect the SCM to the ADC channel 0 and use the DVM data acquisition program in the automatic mode with a 3-s spacing. With blank solution in the sample cell and an SCM gain (g) set to 100, record 10 readings of the voltage. Be sure that the blank signal is much less than 0.5 V but greater than 0.010 V and is close to  $E_{\text{bk}}$  for the 0.1  $\mu\text{g/mL}$  standard. Add comments to the comments box so that you will know what experiment this data represents later when you are working on the report! If the standard deviation is zero, something is wrong - check with one of the instructors. Print and save the file from the DVM program.

The fluctuation in the signal voltage for the blank is used to determine the detection limit (DL). The detection limit is based on an equivalent concentration that yields a signal equal to three times the noise in the blank signal ( $3s_{\text{bk}}$ ), or  $\text{DL} = 3 s_{\text{bk}} / m$ , where  $m$  is the slope of the calibration curve.

## VIII. LAB REPORT

This entire lab report is an individual effort. Your lab report should include: the completed data sheets; the "Summary of Results Sheet"; answers to the following questions; duplicate pages of your lab notebook showing actual sample preparation; copies of the spectra acquired with the commercial PE spectrofluorometer, and copies of the spectra acquired with your PTR station (spreadsheet version). No abstract is required for 2B.

*Section DATA, CALCULATIONS, QUESTIONS*

### III-V

*Spectra on the commercial Perkin Elmer (PE) and PTR (your station) spectrofluorometers.*

1. Include the labeled excitation and emission spectra for the riboflavin standard acquired with the PE.
2. Include the labeled excitation and emission spectra for the sample acquired with the PTR instrument and plotted with Excel.
3. In the report, make a table (four columns) with  
(1 & 2) the wavelength maxima of all *bands in the excitation* spectrum and the wavelength maximum of all bands in the *emission* spectrum obtained with the commercial(PE) spectrofluorometer,  
(3 & 4) the *excitation* wavelength maximum (wavelength that provides the greatest

fluorescence signal) and the *emission* wavelength maximum as observed on the PTR spectrofluorometer.

- Specifically for the copies of the spectra from the PE spectrofluorometer, identify which bands in the excitation spectrum and in the emission spectrum correspond to the scattering band (by labeling the wavelength maxima on the chart) and briefly discuss in a sentence or two how you made this decision for each case. Also identify which bands in the excitation spectrum and in the emission spectrum correspond to the molecular transitions for riboflavin (and label the wavelength maxima on the chart).
- Using the spectra from the PTR fluorometer, report the half-width of the fluorescence band (in nm) and the difference in wavelength between the excitation and emission maxima (in nm). Mark these on your copy of the Excel plot.
- Compare the shapes and relative intensities of bands in the excitation spectrum obtained using the PTR to the those obtained from the PE spectrofluorometer (note: absolute intensities are not comparable for different instruments). Define the differences and indicate some reasons for these differences. Hint: review section III of this manual and eqs. 5 & 6 and your 2B lecture notes.
- Compare shapes and relative intensities of bands in the emission spectrum obtained on the PTR to those obtained from the PE spectrofluorometer (again, absolute intensities taken on different instruments are not comparable) . Discuss differences, similarities and give possible explanations after reviewing this lab manual and lecture notes.

## VI Calibration Data

- Construct an analytical curve of the normalized emission signal ( $E_f'$ ) vs. riboflavin concentration in  $\mu\text{g/mL}$  for the 0.1 - 1.0  $\mu\text{g/mL}$  range. Fit the data to a linear model and report the slope and intercept.
- Use the **linear calibration** determined in VI 1 and calculate the riboflavin concentrations ( $\mu\text{g/mL}$ ) in the synthetic unknown and the three vitamin tablet Z solutions. Report the results in a proper table.
- Use the concentration of each the Z solutions to back-calculate the corresponding mass

(mg) of B2 in the vitamin tablet. **Show an example calculation for one of the samples** (give equation(s) and values from 1 trial with the result). Report the results in a proper table. Also report the mean, the standard deviation, and RSD(%) of the mass (mg) of B2 per vitamin tablet. Compare in a proper table the mean and RSD(%) to the same quantities you obtained in Experiment 2A (section V, question 7).

4. **Plot a second non-linear analytical curve** (different graph and scale) of  $E_f'$  vs. riboflavin concentration in  $\mu\text{g/mL}$  for 1, 2.5, 10, 25, 75, and 100  $\mu\text{g/mL}$ . Fit the data with a non-linear equation and report the exact equation and coefficients determined. Carefully consider your choice for the type of fit (e.g., polynomial, log, etc.) and make sure that the fit to the data is reasonable (e.g.,  $E_f'$  is predicted to be 0 for  $c = 0$  and relative standard errors for the coefficients are not too large). You may find it necessary to exclude the data for the 75 and 100  $\mu\text{g/mL}$  B2 standards to obtain a good fit for the rest of the curve. **Briefly explain in a sentence or two why the plot is not linear.**
5. Is there a background signal above the dark current? If so, what are potential causes of this signal?

## VII *Detection Limit*

1. From the normalized standard deviation of the blank signal and the slope of the calibration curve, calculate the detection limit. The detection limit should be well below 0.1  $\mu\text{g/mL}$  but not zero.
2. What would be the **absorbance** for a solution with a riboflavin of concentration equal to the fluorescence detection limit reported above? Use your calibration curve equation with the slope from experiment 2A and assume a zero intercept.
3. Would you be able to detect this concentration of riboflavin with the absorption technique you used in part 2A? Remember that the minimum detectable absorbance is typically between 0.001 to 0.0001 AU.

Name \_\_\_\_\_ Station # = \_\_\_\_\_ Date \_\_\_\_\_

## DATA SHEET FOR EXPERIMENT 2B. Molecular Fluorescence. CH 461/461H

Synthetic unk # \_\_\_\_\_

VI: PMT bias voltage (HV) = \_\_\_\_\_ V (should be about -400 to -600 V)

Frequency cutoff on SCM = \_\_\_\_\_ Hz (should be 0.3 Hz)

For each standard or sample solution, record  $E_{\text{total}}$  and measure a new blank and record  $E_{\text{blank}}$ . Promptly calculate the fluorescence signal  $E_f$  (eq. 7) and normalized fluorescence signal  $E_f'$  calculated as  $E_f/\text{gain}$ . All fluorescence signals are normalized back to the value at the output of the PMT module by dividing by the SCM gain. Assume that  $g$  is known to three significant figures. Start a chart in Excel as you collect the data. Recall that:  $E_{\text{total}} = E_f + E_{\text{blank}}$

Dark current voltage ( $E_d$ ) = \_\_\_\_\_ V (measure once)

Table I. Fluorescence Calibration Data

Conc. ( $\mu\text{g/mL}$ )	$E_{\text{total}}$ (V)	$E_{\text{blank}}$ (V)	$E_f$ (V)	SCM Gain (g) (note changes)	$E_f'$ (V)
100				<b>1.00</b>	
75				<b>1.00</b>	
25				<b>1.00</b>	
10				<b>1.00</b>	
2.5				<b>2.00</b>	
1.0				<b>5.00</b>	
0.25				<b>20.0</b>	
0.1				<b>100</b>	
syn. unknown				<b>20.0</b>	
Z1				<b>20.0</b>	
Z2				<b>20.0</b>	
Z3				<b>20.0</b>	

## VII: Detection Limit Data

Include the computer printout of repetitive blank measurements and report the following:

mean blank voltage = \_\_\_\_\_

standard deviation in blank voltage = \_\_\_\_\_

gain on SCM = \_\_\_\_\_

gain normalized standard deviation (referenced to PMT module output gain) = \_\_\_\_\_  
(the normalization is the same as used previously)

Show calculation of gain normalized standard deviation:

## SUMMARY OF RESULTS SHEET FOR EXPERIMENT 2B

Section II: Solution Preparation - Mass data same as that given in experiment 2A (+/- 0.1 mg)

mass of whole vitamin tablet	
mass of sample for solution X1	
mass of sample for solution X2	
mass of sample for solution X3	

Any requested proper Tables and short answers to questions on pages 14-15 PLUS the following summary:

Question	Information Requested	Numerical value (with units)
V. 1.	with the PTR fluorometer: emission wavelength maximum half-width of emission band	_____ nm _____ nm
V1. 1.	equation for regression curve for linear region (normalized signal vs conc.)	
2.	B2 concentration in the synthetic unknown	_____ $\mu\text{g/mL}$
3.	mean and RSD of amount of B2 in tablet found with fluorometry (this study)  mean and RSD of amount of B2 in tablet found with absorption spectrophotometry (from exp. 2A)	_____ mg/tablet 2B _____ RSD 2B  _____ mg/tablet 2A _____ RSD 2A
VII. 1.	normalized standard deviation in the blank voltage  detection limit	_____ V  _____ $\mu\text{g/mL}$
2.	absorbance for a solution of riboflavin of concentration equal to the above detection limit	_____ AU